

QUOTATION

Quote # 2002562A
November 8, 2002

Casting Fool & Son
PO Box 16143
Augusta, GA

Attn: Mr. Mike Jackson
Ph: 706-651-0617
Fax: 706-651-0544

Sub: Small casting autoclave

Ref: Your web request.

Per your request we are pleased to provide the following proposal for a small casting autoclave.

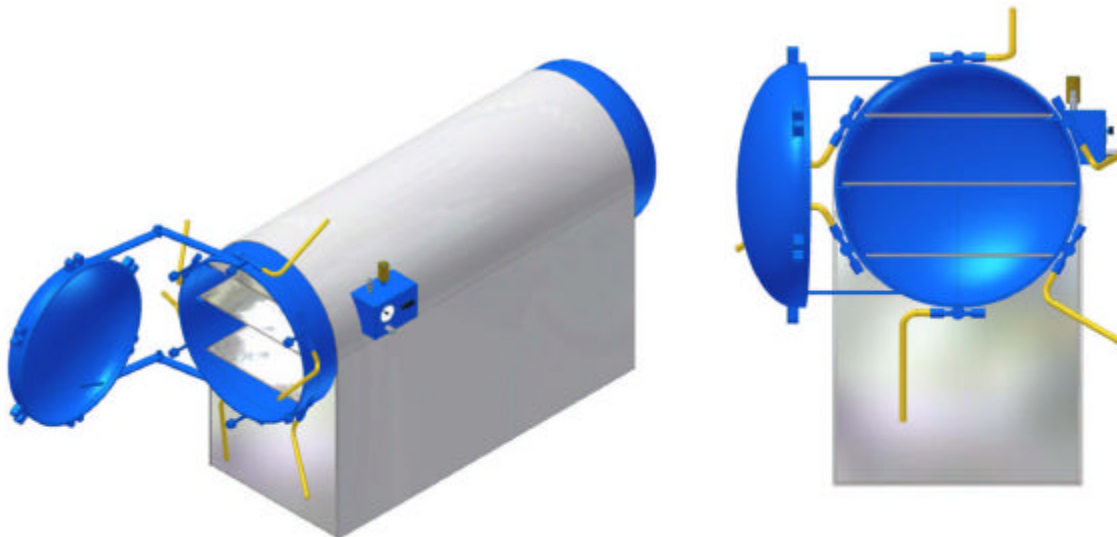

ASC standard CastoClave™

CastoClave™ CC-18X48-50P

Designed specifically for sub-scale casting production and research & development activities, it is the most economical vessel for casting available on the market.

Specifications

- 18" diameter x 48" working length
- 50 Psig maximum working pressure
- Pressure inlet control valve
- Pressure exhaust valve
- Over Pressure Relief Valve
- Quick opening Camlock™ door – The Camlock™ assembly eliminates the need of a wrench

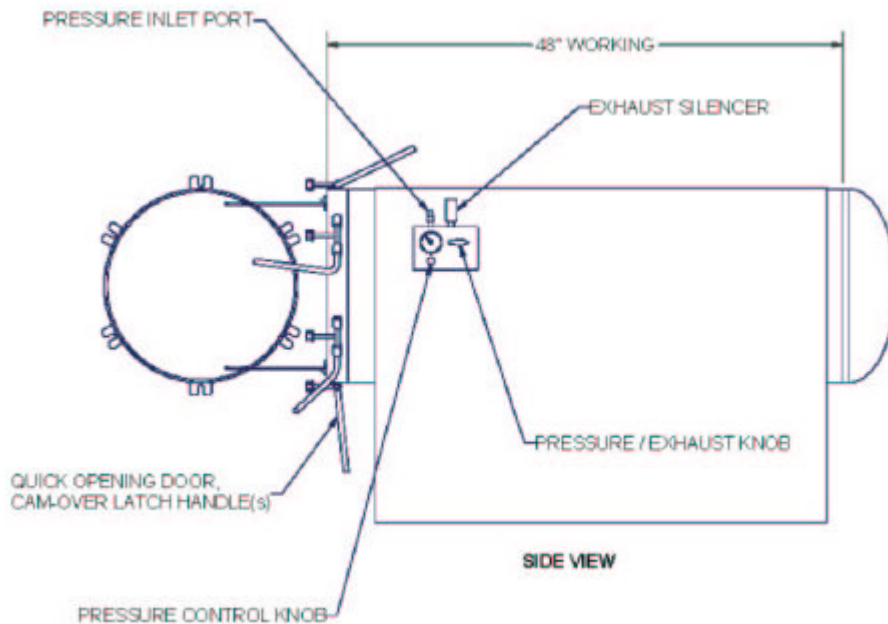

ASC Process Systems, Inc.

20765 Superior Street – Chatsworth, California, 91311 – USA

818-349-4272 – www.aschome.com

Utility requirements

The vessel above requires the following utilities:

- Compressed N2 or Air @ 80 psig minimum.
- Vent hood if using nitrogen to pressurize.

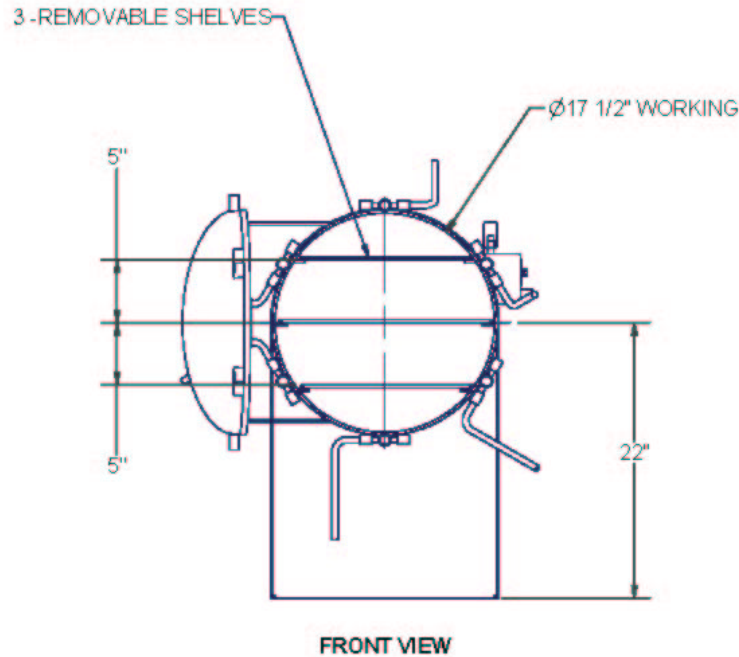

Price - Model # CC-18X48-50P50:

- 1) One CastoClave™ model CC-18X48-50P \$3,950.00

Terms

- 50% down payment
- 40% upon receipt of major components at ASC, net 30 days
- 10% upon shipment of autoclave, net 30 days

ASC Process Systems, Inc.
20765 Superior Street – Chatsworth, California, 91311 – USA
818-349-4272 – www.aschome.com

Delivery

6-7 weeks after receipt of down payment

Quote Validity

30 days.

Thank you for the opportunity to submit this quotation. If you should have any questions, please do not hesitate to call or email.

Sincerely,

ASC Process Systems, Inc.

Mark Montoya